

K7EFG0515

ELECTRIC FRYER SINGLE TANK 15 lt. - PERFORMANCE LINE



PRODUCT DESCRIPTION

Stainless steel frame. Athermic thermoset plastic knobs with useful screen printed edges. Double-skinned door and sturdy handle. Oil heating obtained through **stainless steel heating elements**, immersed in oil and **easily tilting** for easy cleaning operations.

15 lt. tank provided with a thermostat, which enables the temperature to be regulated between 100°C and 190°C.

Manually-reactivating safety thermostat.

Stainless steel tank with rounded edges sloping towards the drain spout that is connected to a stainless steel oil container.

Moulded work surface and tank for easy cleaning. Stainless steel front, side and back panels.

Standard equipped with stainless steel oil container with filter. **Standard equipped** with one stainless steel basket K26237 and one tank lid K7COPFGP.

Laser-cut work top finishing for "head-to-head" matching and binding fastening.

Height-adjustable stainless steel legs.

Accessories available **on demand**.



TECHNICAL SPECIFICATIONS

Width: 400 mm
Depth: 700 mm
Height: 850 mm
Weight: 42 kg
Volume: 0.45 m³
Electrical power: 15.00 kW



K7EFG0515

FRIGGITRICE ELETTRICA 15 LT. - FRITEUSE ÉLECTRIQUE 15 LT. - ELECTRIC FRYER 15 LT. - ELEKTROFRITTEUSE 15 LT. - FREIDORA ELÉCTRICA 15 LT. - ФРИТЮРНИЦА ЭЛЕКТРИЧЕСКАЯ 15 Л.

DATI TECNICI / CARACTERISTIQUES TECHNIQUES / TECHNICAL SPECIFICATIONS / TECHNISCHE DATEN / CARACTERISTICAS TECNICAS / ТЕХНИЧЕСКИЕ ХАРАКТЕРИСТИКИ

Dimensioni / Dimensions / Dimensions / Maße / Medidas / Размеры	[мм]	400x700x850
Potenza elettrica / Puissance électrique / Electric Power / Elektro-Leistung / электр. (E)	[Kw] - [кВт]	15
(F)	[V]	400/3N
(G)	[Hz] - [Гц]	50/60
Cavo (non fornito in dotazione) / Cable (non fourni) / Cable (not supplied) / Kabel (nicht mitgeliefert) / Cable / Кабель	H07 RN-F [мм ²]	5 x 4
Voltaggi diversi e versioni navali disponibili su richiesta / Différentes tensions et versions maritimes disponibles sur demande / Different voltages and marine versions available on request / Verschiedene Spannungen und Schiffsausführungen auf Anfrage erhältlich / Различные напряжения и варианты исполнения корабля - по запросу		
Capacità vasca / Capacité cuve / Tank capacity / Beckeninhalt / Capacidad cuba / Ёмкость чаши	[L] [л]	15
Quantità di patate massima contenuta in un cesto grande - Quantité maximale de pommes de terre dans un grand panier - Maximum quantity of potatoes in a large basket - Maximale Menge an Kartoffeln in einem großen Korb - Cantidad máxima de patatas en una cesta grande - Максимальное количество картофеля в большой корзине	[kg] [кг]	2
Produzione massima - Production maximale - Maximum output - Maximale Leistung - Producción máxima - Максимальное производство	[kg/h] [кг/ч]	22

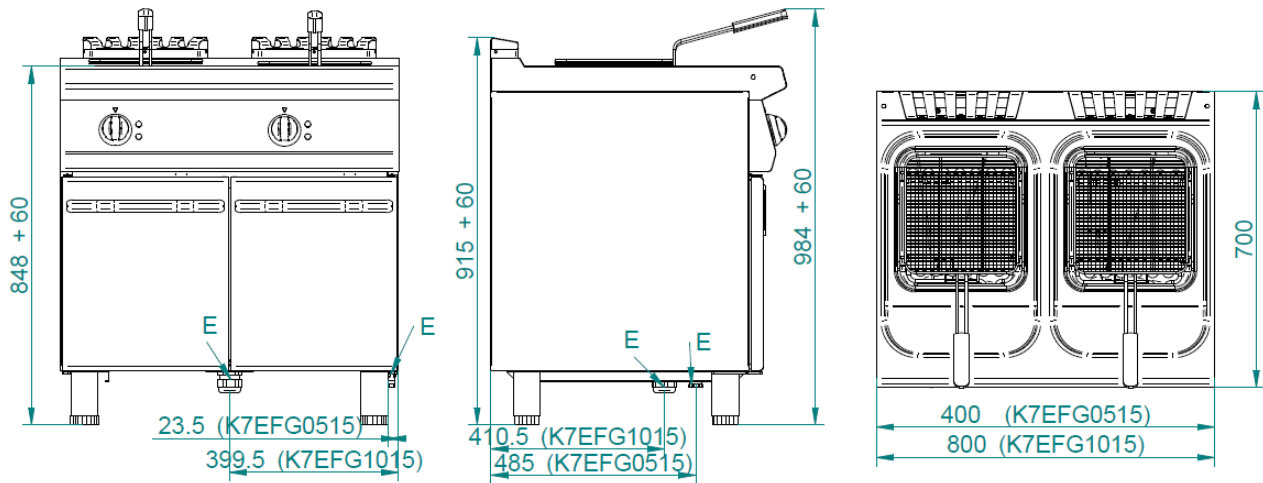



E= elettrico \ électrique \ electric \ Elektrisch \ eléctrico \ электрич

Standard

		Mm	
	K26237	a 280 b 270 h 111	Cesto friggitrice 1/1 Panier friteuse 1/1 Basket for fryer 1/1 Korb für Fritteuse 1/1 Cesta freidora 1/1 Корзина для фритюрницы 1/1
	C2VOFG		Bacinella raccogli olio + Filtro inox Bac de récupération d'huile + filtre en acier inoxydable Container for collecting oil + stainless steel filter Ölauffangwanne + Edelstahlfilter Recipiente de recogida de aceite + filtro de acero inoxidable Емкость для сбора масла + фильтр нержавеющей сталь
	K7COPFGP		Lid for gas fryer Coperchio per friggitrice a gas Couvercle pour friteuse à gaz Deckel für Gasfritteuse Tapa para freidora a gas Крышка для газовой фритюрницы

Accessori - Accessoires - Accessories - Zubehöre -

Accesorios - Аксессуары

	K26238	a 280 b 130 h→111	Cesto friggitrice 1/2 Panier friteuse 1/2 Basket for fryer 1/2 Korb für Fritteuse 1/2 Cesta freidora 1/2 Корзина для фритюрницы 1/2
	K00088		Kit giunzione serie 700/600 Kit connexion série 700/600 Connecting kit series 700/600 Verbindungssatz Serie 700/600 Kit conexión serie 700/600 Комплект соединяющие части серия 700/600