

K7GCPP05

GAS PASTA COOKER SINGLE TANK 26 LT.



PRODUCT DESCRIPTION

Stainless steel frame. Athermic thermoset plastic knobs with useful screen printed edges.

Heating obtained through **tubular burner with stabilized stainless steel flame**, with thermocouple safety valve and protected pilot flame. Power and quick intervention of the burners in order to avoid the temperature lowering when the product is poured into the tank. Equipped with a safety gas cock that allows to adjust the power **from maximum to minimum**. Safety guaranteed by a thermocouple kept active by the pilot burner flame.

AISI 304 stainless steel worktop with rounded edges for easy cleaning. Front, side and back coverings in stainless steel.

Cooking tank (**capacity of 26 litres**) made with AISI 316 cold moulding, resistant to salt water and starch, with touch zone and starch evacuation, drainage hole and small perforated stainless steel front surface for supporting the baskets.

Tap for filling and refilling water positioned on the front panel. Tank drain positioned inside the machine to avoid accidental openings.

Drain fitting made entirely of AISI 316 stainless steel.

Laser-cut work top finishing for "head-to-head" matching and binding fastening.

Tested with natural gas or LPG, according to the user's needs.

Height-adjustable stainless steel legs.

Accessories available **on demand**.



TECHNICAL SPECIFICATIONS

Width: 400 mm
Depth: 700 mm
Height: 850 mm
Weight: 49 kg
Volume: 0.45 m³
Gas power: 8.70 kW



K7GCPP05

CUOCIPASTA A GAS 26 LT // CUISEUR A PATES A GAZ 26 LT. // GASNUDELKOCHER 26 LT. //
CUECE PASTA A GAS 26 LT. // ГАЗОВЫЕ МАКАРОНОВАРКИ

DATI TECNICI / CARACTERISTIQUES TECHNIQUES / TECHNICAL SPECIFICATIONS /
TECHNISCHE DATEN / CARACTERISTICAS TECNICAS / ТЕХНИЧЕСКИЕ ХАРАКТЕРИСТИКИ

Dimensioni / Dimensions / Dimensions / Maße / Medidas / Размеры	[мм]	400x700x850
Gas / Gaz / Gas / Gas / Газ (B)	[Kw] - [кВт]	8,7
Tipo / Type / Type / Typ / Тип (A)		A1
GPL/LPG / Сжиженный нефтяной газ (G30) (D)	[Kg/h] [кг/ч]	0,6860
Metano / Methane / Natiral gas / Erdgas / Метан (G20) (C)	[m3/h] [м3/ч]	0,9206
Racc. Gas / Racc. Gaz / Gas fitting / Gasanschluss / Empalme gas / Газовое соединение		UNI-ISO 7/1 R ½
Capacità vasca/ Capacité cuve/ Tank capacity/ Beckeninhalte/ Capacidad cuba / Ёмкость чаши	[Lt] [л]	26
Racc. acqua/Racc. eau/Water fitting/Wasseranschluss/ Empalme agua/ Фитинг воды/		UNI-ISO 7/1 R ½
Press. Acqua/Pression eau/Water pressure//Wasserdruck/Presion agua/ Давл. Воды MAX	[kPa]	300

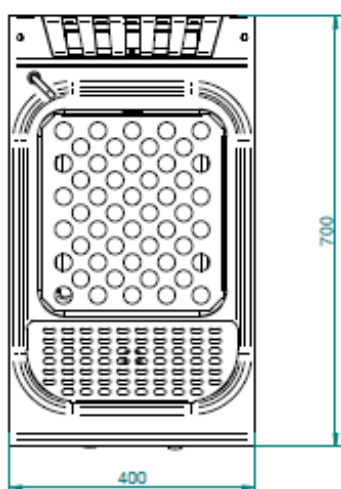
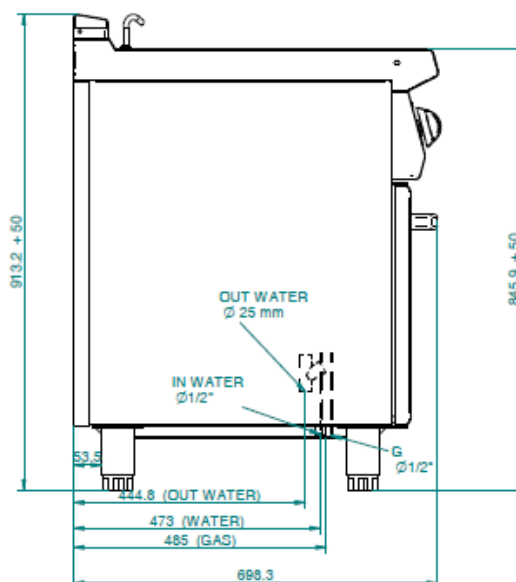
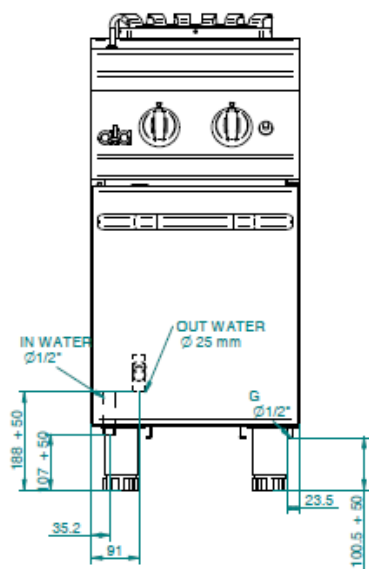

G = Gas / Gaz / Gas / Gas / Gas / газ

C ($\varnothing 1/2"$) = Carico acqua \ Remplissage d'eau \ Water filling \ Wasser anfüllen \ Carga agua \ Заливка воды

S D - S ($\varnothing 1"$) = Scarico acqua \ Évacuer l'eau \ Water emptying \ Wasser entleeren \ Descarga agua \ Слив воды

Standard

Vasca e raccorderia inox AISI 316 – Cuve et raccords inox AISI 316 – Tank und Verbindungsstück aus Edelstahl AISI 316 – Cuba y conexiones de acero AISI 316 - Емкость и арматура нержавеющей сталь AISI 316

Optional

N. 2 x **K26028** Cesti - Paniers - Baskets - Körbe - Cestas - Корзины

Configurazioni per vasca - Configurations cuves – Configuration possibilities - Behältermöglichkeiten
Configuraciones recipientes - Конфигурации ванн

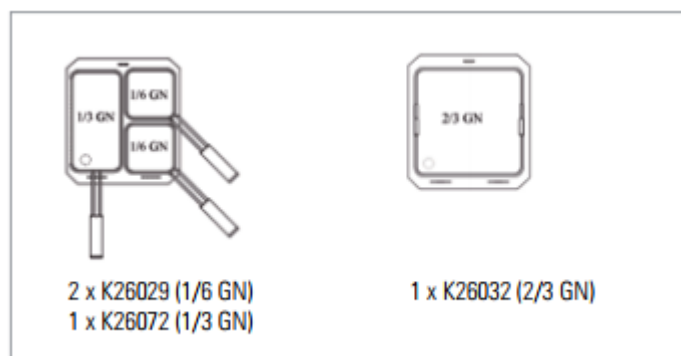
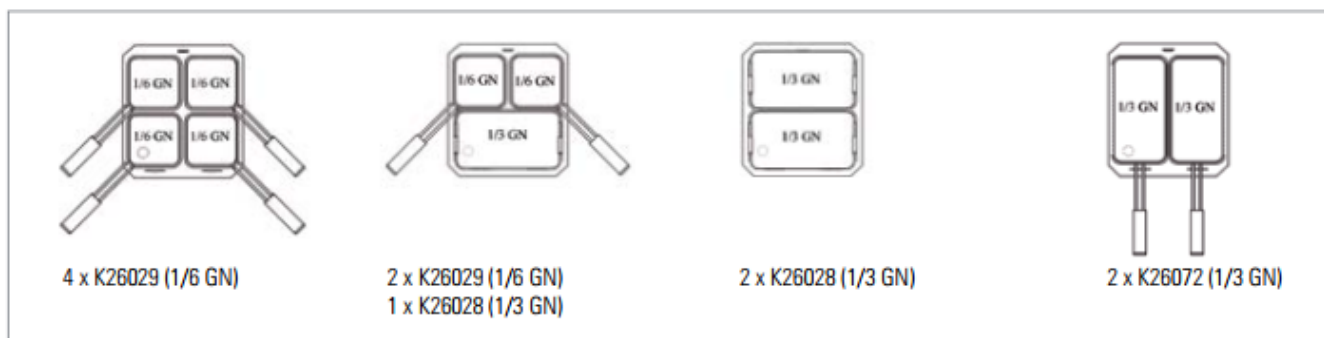

Accessori - Accessoires - Accessories - Zubehöre - Accesorios - Аксессуары

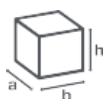

Mm

K26028

 a 160
 b 290
 h 200

Cesto cuocipasta 1/3 GN - Panier pour cuiseur à pâte 1/3 GN - Basket for pasta cooker 1/3 GN - Korb für Nudelkocher 1/3 GN - Cesta para cuece-pasta 1/3 GN - Корзина для макаронотварки 1/3 GN

K26032

 a 290
 b 290
 h 200

Cesto cuocipasta 2/3 GN - Panier pour cuiseur à pâte 2/3 GN - Basket for pasta cooker 2/3 GN - Korb für Nudelkocher 2/3 GN - Cesta para cuece-pasta 2/3 GN - Корзина для макаронотварки 2/3 GN

K26029

 a 140
 b 140
 h 200

Cesto cuocipasta 1/6 GN - Panier pour cuiseur à pâte 1/6 GN - Basket for pasta cooker 1/6 GN - Korb für Nudelkocher 1/6 GN - Cesta para cuece-pasta 1/6 GN - Корзина для макаронотварки 1/6 GN

K26072

 a 290
 b 140
 h 200

Cesto cuocipasta 1/3 GN - Panier pour cuiseur à pâte 1/3 GN - Basket for pasta cooker 1/3 GN - Korb für Nudelkocher 1/3 GN - Cesta para cuece-pasta 1/3 GN - Корзина для макаронотварки 1/3 GN

C2COPCP

 a 340
 b 258
 h 85

Coperchio per cuocipasta - Couvercle pour cuisier à pâte - Lid for pasta cooker - Deckel für Nudelkocher - Tapa para cuece-pasta - Крышка для макаронотварки