



PLANETARY MIXER BM-5E

Table-top model with 5 l / qt bowl.



DYNAMIC PREPARATION
PLANETARY MIXERS



SALES DESCRIPTION

Designed for light duty use.

Professional food mixer for preparing dough (bread, cake...), egg whites (soufflés, meringue...), sauces (mayonnaise...) and minced meat mixtures.

- ✓ Compact model, ideal for establishments of up to 50 seats.
- ✓ Continuous variable electronic speed control.
- ✓ Equipped with an extractible safety guard.
- ✓ Lever operated bowl lift.
- ✓ Double micro switch for bowl position and safety guard.
- ✓ NSF-International certified appliance (complying with Hygiene, Cleaning and Food Material regulations).

INCLUDES

- ✓ Stainless steel bowl.
- ✓ Beater spatula for soft dough.
- ✓ Spiral hook for heavy dough.
- ✓ Balloon whisk.

ACCESSORIES

- Bowls for planetary mixers

SPECIFICATIONS

Bowl capacity: 5 l
Bowl dimensions: 208 mm x 197 mm
Capacity in flour (50% water): 1 kg
Tool speed: 98 - 455 rpm
Planetary speed: 40 - 187 rpm
Total loading: 300 W

External dimensions (W x D x H)

✓ Width: 310 mm
✓ Depth: 382 mm
✓ Height: 537 mm
Net weight: 13.7 kg
Noise level (1m.): <80 dB(A)
Background noise: 45 dB(A)
Crated dimensions
360 x 430 x 565 mm
Gross weight: 17 kg

AVAILABLE MODELS

1500180 Food mixer BM-5E 230/50-60/1
1500185 Food mixer BM-5E 120/60/1

* Ask for special versions availability



SAMMIC, S.L. · Basarte, 1
20720 AZKOITIA (Gipuzkoa) · SPAIN

product sheet
updated 20/11/2025



PLANETARY MIXER BM-5E

Table-top model with 5 l / qt bowl.



DYNAMIC PREPARATION
PLANETARY MIXERS

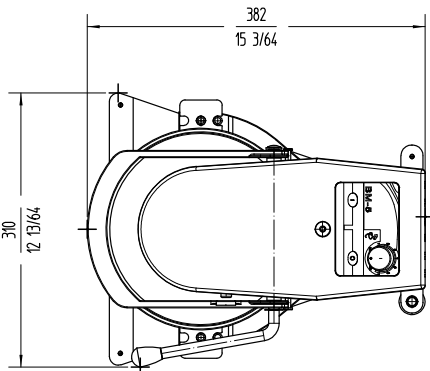
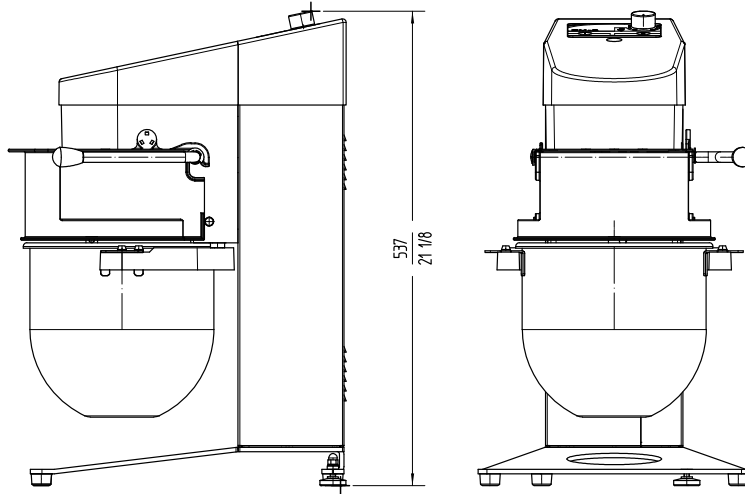

sammic | sammic.com
Food Service Equipment Manufacturer

Polígono Basarte, 1. phone +34 943 15 72 36
20720 Azkoitia, Spain sales@sammic.com



Project	Date
Item	Qty
Approved	

product sheet
updated 20/11/2025