



FOOD-PROCESSOR K-41

Bowl capacity: 4.4 l. 1 speed.



DYNAMIC PREPARATION
CUTTER-MIXERS & EMULSIFIERS

SALES DESCRIPTION

Compact ACTIVE line. 1-speed motor block + 4.4 l cutter bowl with lateral stirrers and toothed blades.

Efficiency and performance.

- ✓ 4.4 lt-bowl equipped with lateral stirrer and high shaft for larger production capacity.
- ✓ Transparent lid equipped with hole to add ingredients in use.
- ✓ Lid complete with gasket to avoid product overflowing.
- ✓ Homogeneous and fine mixing result thanks to the lateral stirrers and invert-blade technology.
- ✓ The lateral stirrers avoid product overheating.
- ✓ Very uniform finish due to the movement generated the special position of the cutting edges.
- ✓ Depending on usage, optional smooth or perforated blades available.
- ✓ Optional vegetable slicer attachment available.

Built to last

- ✓ Sturdy construction in food-grade best quality materials.
- ✓ High power asynchronous motor.

Maximum comfort for the user

- ✓ Cutter bowl equipped with ergonomic handle.
- ✓ The electronic command panel is very intuitive.
- ✓ Recessed cord relief allowing flush against wall operation

Maintenance, safety, hygiene

- ✓ Safety microswitches in the position of the bowl and the lid.
- ✓ Complete error warning system.
- ✓ Appliance certified by NSF International (regulations on hygiene, cleaning and materials suitable for contact with foods).
- ✓ 100% tested.

INCLUDES

- ✓ 1-speed motor block.
- ✓ Built-in lateral stirrers.
- ✓ Cutter bowl with toothed blades.

OPTIONAL

- Hub with smooth blades.
- Vegetable slicer attachment.
- Hub with perforated blades.

ACCESSORIES

- Cutter bowl
- Vegetable preparation attachment for K-41 / KE-4V
- Hubs with blades

SPECIFICATIONS

Bowl capacity: 4.4 l
 Max. product capacity: 2.5 kg
 Maximum capacity (liquid): 2.4 l
 Bowl dimensions: Ø193 mm x 161 mm
 Total loading: 800 W
 Speed, min-max: 1500 rpm

External dimensions (W x D x H)

- ✓ Width: 252 mm
 - ✓ Depth: 309 mm
 - ✓ Height: 434 mm
- Net weight: 14.2 kg
 Crated dimensions
 285 x 385 x 695 mm
 Volume Packed: 0.08 m³
 Gross weight: 18.4 kg

AVAILABLE MODELS

1050980	Cutter K-41 230/50/1
1050986	Cutter K-41 220/60/1
1050992	Cutter K-41 120/60/1

* Ask for special versions availability



SAMMIC, S.L. · Basarte, 1
20720 AZKOITIA (Gipuzkoa) · SPAIN

product sheet
updated 17/12/2025



FOOD-PROCESSOR K-41

Bowl capacity: 4.4 l. 1 speed.



DYNAMIC PREPARATION
CUTTER-MIXERS & EMULSIFIERS

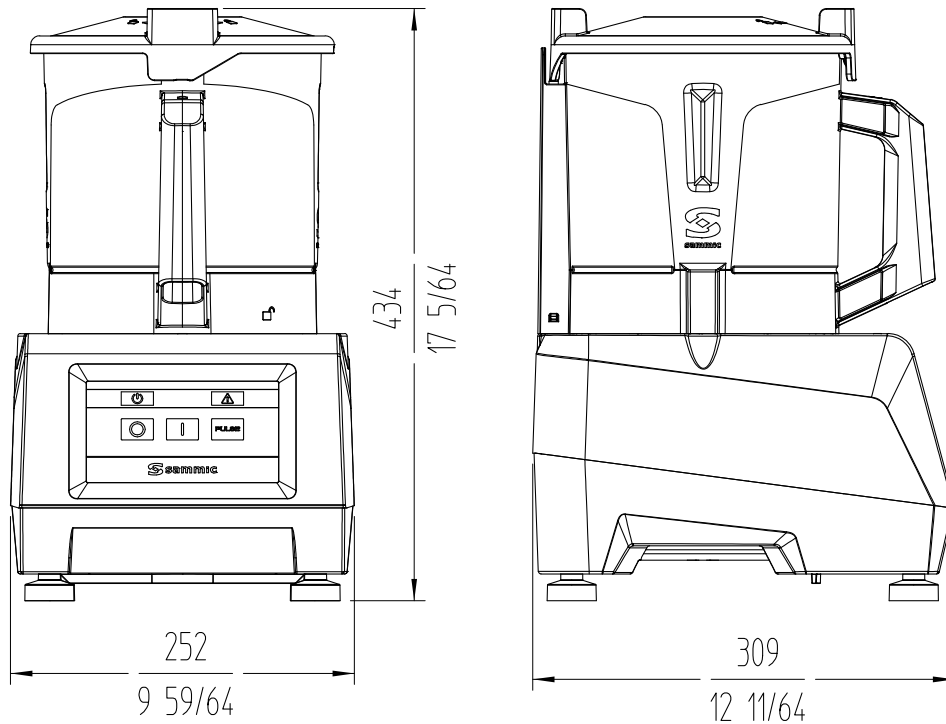

 **sammic** | sammic.com
Food Service Equipment Manufacturer

Polígono Basarte, 1. phone +34 943 15 72 36
20720 Azkoitia, Spain sales@sammic.com



Project	Date
Item	Qty
Approved	

product sheet
updated 17/12/2025