



VACUUM SEALER SE-810 LL

Floorstanding unit. 100 m³/h. 848 + 848 mm.



FOOD PRESERVATION AND SOUS-VIDE
COMMERCIAL VACUUM PACKING MACHINES

SALES DESCRIPTION

Two sealing bars (848 + 848 mm).
100 m³/h Busch vacuum pump.
Vacuum controlled by sensor.

- ✓ Powered by Busch.
- ✓ Vacuum controlled by sensor.
- ✓ Vacuum PLUS.
- ✓ Digital keyboard.
- ✓ Control panel equipped with display indicating the exact vacuum percentage.
- ✓ "Pause" button to marinate food.
- ✓ Safe liquid packing thanks to sensor control.
- ✓ Double seal.
- ✓ Cordless sealing bar.
- ✓ Bag-sealing programme.
- ✓ Pulse-controlled decompression.
- ✓ Vac-Norm ready with Automatic decompression.
- ✓ Stainless steel body and chamber.
- ✓ Damped transparent lid.
- ✓ Dry-oil programme for drying the pump.
- ✓ Working hours counter for oil changes.
- ✓ Safety system with protection against vacuum failure.
- ✓ NSF-listed model.

INCLUDES

- ✓ Sensor controls.
- ✓ Up to 10 seconds of extra vacuum pull.
- ✓ Soft air function.
- ✓ Dry oil cycle.
- ✓ BUSCH pump.
- ✓ NSF approved.
- ✓ Clear methacrylate lid.
- ✓ Filling plate.

OPTIONAL

- Vacuum packing bags.
- External vacuum kit for Vac-Norm, containers and accessories.
- Bag cutting kit.
- Support for liquid packaging.
- Additional filling plates.

ACCESSORIES

- Bag cutting kits
- Filling plates
- Liquid insert plates
- Vac-norm external vacuum kit
- Vac-norm containers
- Smooth bags for vacuum packing
- Vacuum packing machines maintenance kits

SPECIFICATIONS

Pump capacity: 100 m³/h
Pump capacity (60 Hz): 120 m³/h
Bar length: 848 + 848 mm
Total loading: 2200 W

Internal dimensions

- ✓ Width: 864 mm
- ✓ Depth: 603 mm
- ✓ Height: 215 mm

External dimensions (W x D x H)

- ✓ Width: 960 mm
- ✓ Depth: 757 mm
- ✓ Height: 998 mm

Net weight: 250 kg
Noise level (1m.): 75 dB(A)
Background noise: 32 dB(A)
Crated dimensions
1060 x 840 x 1200 mm
Gross weight: 291 kg

AVAILABLE MODELS

1140698 SE-810 LL 400/50-60/3N
1140706 SE-810 LL 208-240V/60/3

* Ask for special versions availability





VACUUM SEALER SE-810 LL

Floorstanding unit. 100 m³/h. 848 + 848 mm.



FOOD PRESERVATION AND SOUS-VIDE
COMMERCIAL VACUUM PACKING MACHINES

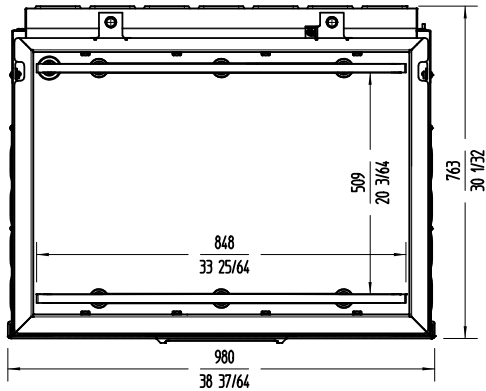
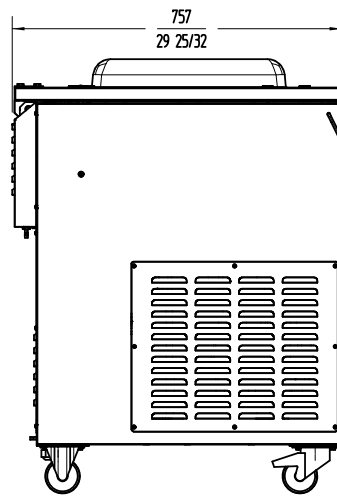
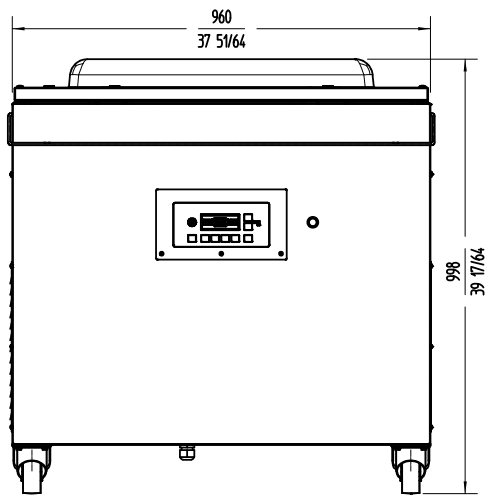

sammic | sammic.com
Food Service Equipment Manufacturer

Polígono Basarte, 1. phone +34 943 15 72 36
20720 Azkoitia, Spain sales@sammic.com



Project	Date
Item	Qty
Approved	

product sheet
updated 03/12/2025