



SPZLR0AER00

HIGH-SPEED CONVECTION OVEN
2,4" LCD DIGITAL CONTROL

FUNCTIONAL CHARACTERISTICS

Display	DIGITAL
Supply	ELECTRIC
Timer	-
Number of motors	1
Motor speeds	5 speed + inverter
Max cooking temperature	260 °C
Probe	Single point PT1000
Cooking chamber material	AISI 304
Opening door	Flap door
Chimney	20 mm open
Humidification	-
Air injection	-
Version	Standard
Venteless	-



STANDARDS	
Certification	CE
TRAYS	
Trays rack	sheet metal single level
Max tray load	3 kg
DIMENSIONS	
Oven size with handle WxDxH	460 x 655 x 525 mm
Oven size without handle WxDxH	460 x 610 x 525 mm
Chamber size WxDxH	320 x 315 x 215 mm
Unit weight	36 kg
PACKAGING	
Packaging	CARTON BOX
Packaging size WxDxH	544 x 694 x 570
Unit weight with packaging	48,4 kg
Crate packaging size (optional)	510 x 720 x 670 mm
Unit weight with crate packaging (optional)	61,8 kg
ELECTRICAL DATA	
HEATERS 3,1kW 50/60Hz	
Power	3,4kW
Frequency	50/60Hz
Power supply	220-240 V ~
Amperage	14,8A
Power cord req.	3G1,5
WATER CONNECTION REQUIREMENTS	
Humidification Water Inlet	-
Washing Water Inlet	-
Water drain	-
Max water hardness	-
Water pressure requirement min-max	-
CONSUMPTION	
Humidification Water with solenoid valve	-
Humidification Water with pump	-
Rinse Water @2barG	-



Short Washing Water @2barG	-
Long Washing Water @2barG	-
Short Washing Detergent *	-
Long Washing Detergent *	-

CONNECTIVITY

USB	USB 2.0
Bluetooth	
Wi-Fi	STANDARD
Cloud	STANDARD

ACCESSORIES

Pizza paddle	SPZFLA (optional)
Panini paddle	SPZSHO (optional)
Pizza tray	GRI00327 (optional)
Perforated pizza pan	GRI00406 (Optional)
Panini grid	GRI00310 (optional)
Crumbs tray	VAS00080 (included)
Teflon sheet 270x270	GPP00086 (optional)
Teflon sheet 305x305	GPP00088 (optional)
Teflon tray 305x305 H24	GPP00087 (optional)
Hood	POSPZ*



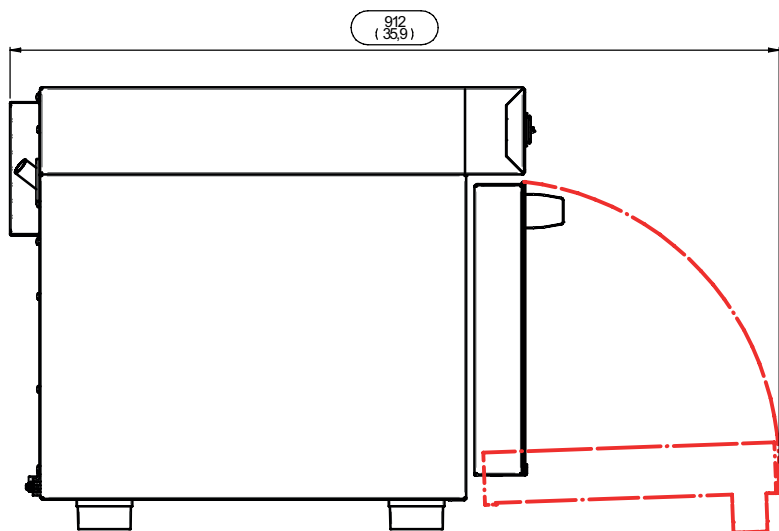
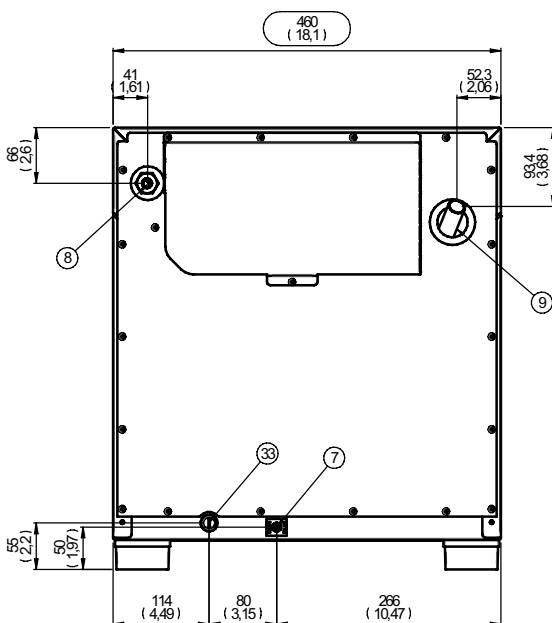
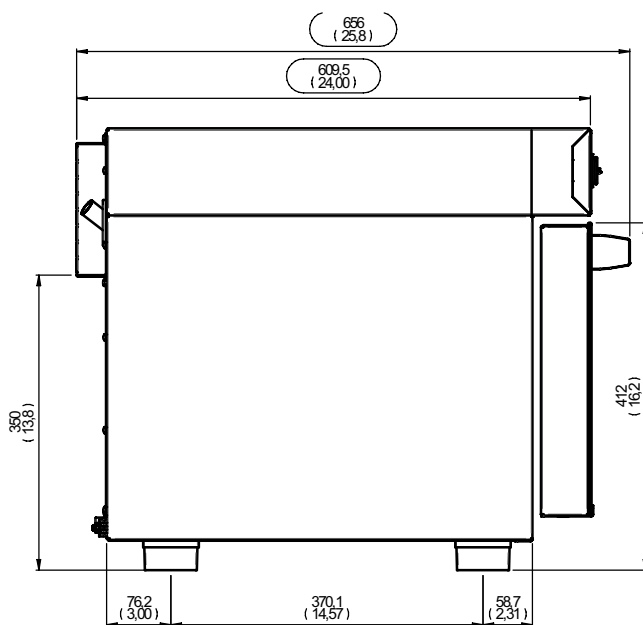
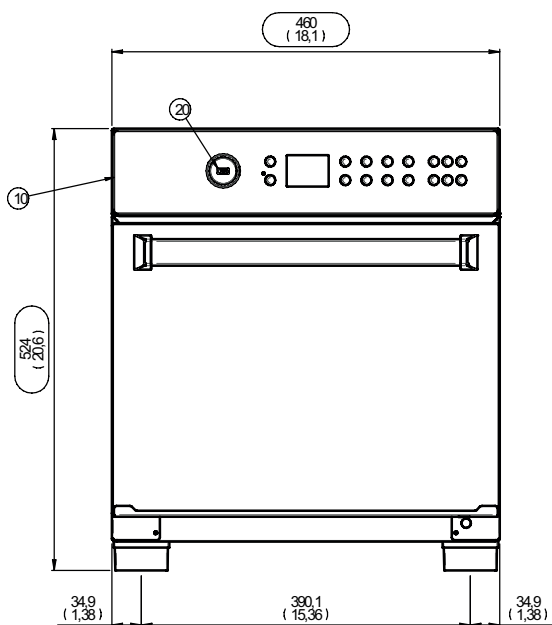

07.	UNIPOTENTIAL TERMINAL
08.	COMPRESSION CABLE GLAND
09.	HOT FUMES EXHAUST CHINMEY (Ø 20MM)
10.	DIGITAL CONTROL
20.	USB CONNECTION
33.	SAFETY THERMOSTAT

